

Please check the examination details below before entering your candidate information

Candidate surname					Other names				
Centre Number				Candidate Number					
<input type="text"/>	<input type="text"/>	<input type="text"/>	<input type="text"/>	<input type="text"/>	<input type="text"/>	<input type="text"/>	<input type="text"/>		
<b>Pearson Edexcel International Advanced Level</b>									
<b>Wednesday 15 January 2025</b>									
Afternoon (Time: 1 hour 45 minutes)					Paper reference		<b>WPH15/01</b>		
<b>Physics</b>									
<b>International Advanced Level</b>									
<b>UNIT 5: Thermodynamics, Radiation, Oscillations and Cosmology</b>									
<b>You must have:</b> Scientific calculator, ruler							Total Marks		

## Instructions

- Use **black** ink or ball-point pen.
- If pencil is used for diagrams/sketches/graphs it must be dark (HB or B).
- **Fill in the boxes** at the top of this page with your name, centre number and candidate number.
- Answer **all** questions.
- Answer the questions in the spaces provided  
– *there may be more space than you need.*
- **Show all your working out** in calculations and **include units** where appropriate.

## Information

- The total mark for this paper is 90.
- The marks for **each** question are shown in brackets  
– *use this as a guide as to how much time to spend on each question.*
- In the question marked with an **asterisk (\*)**, marks will be awarded for your ability to structure your answer logically, showing how the points that you make are related or follow on from each other where appropriate.
- The list of data, formulae and relationships is printed at the end of this booklet.

## Advice

- Read each question carefully before you start to answer it.
- Try to answer every question.
- Check your answers if you have time at the end.

Turn over ►

P78479A

©2025 Pearson Education Ltd.  
H:1/1/1/



  
Pearson

## SECTION A

Answer ALL questions.

For questions 1–10, in Section A, select one answer from A to D and put a cross in the box . If you change your mind, put a line through the box  and then mark your new answer with a cross .

- 1 A main sequence star evolves into a red giant star.

Which row of the table gives the change in diameter and the change in surface temperature when the star evolves?

	Diameter of star	Surface temperature of star
<input type="checkbox"/> A	decreases	decreases
<input type="checkbox"/> B	decreases	increases
<input type="checkbox"/> C	increases	decreases
<input type="checkbox"/> D	increases	increases

(Total for Question 1 = 1 mark)

- 2 Ductile materials can be used in buildings to reduce the amplitude of forced oscillations during an earthquake.

Which of the following is the reason that ductile materials are used?

- A These materials are stiff.  
 B These materials are strong.  
 C These materials deform elastically.  
 D These materials deform plastically.

(Total for Question 2 = 1 mark)

- 3 There is an electric field around a point charge and a gravitational field around a point mass.

Which of the following is **not** correct?

- A Both fields are radial.  
 B Both fields can produce attractive forces.  
 C Both fields can produce repulsive forces.  
 D Both fields produce forces that obey an inverse square law.

(Total for Question 3 = 1 mark)



- 4 The graph shows how the binding energy (B.E.) per nucleon varies with the number of nucleons. The positions of three isotopes, P, Q and R, are marked on the curve.

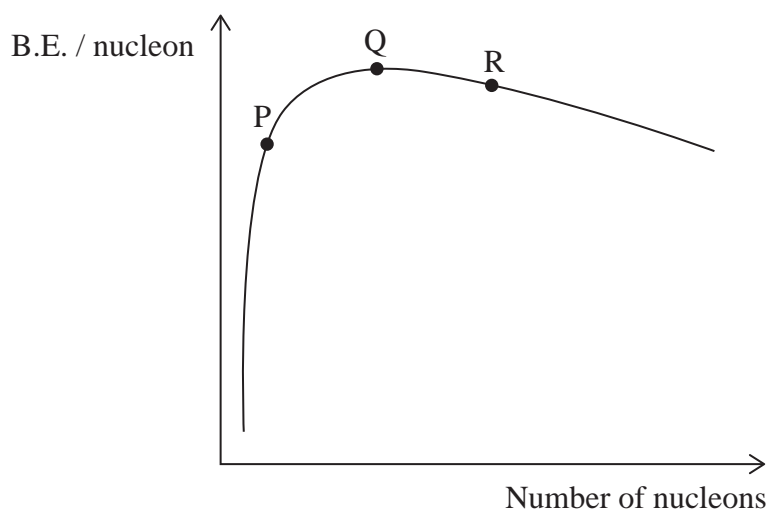

Which row of the table lists the isotopes from least stable to most stable?

		Least stable	—————>	Most stable
<input type="checkbox"/>	<b>A</b>	P		Q R
<input type="checkbox"/>	<b>B</b>	P		R Q
<input type="checkbox"/>	<b>C</b>	Q		R P
<input type="checkbox"/>	<b>D</b>	R		P Q

(Total for Question 4 = 1 mark)

- 5 Astronomers use trigonometric parallax to determine the distances to stars.

Which of the following must the astronomers know?

- A** The distance between the Sun and a nearby star
- B** The diameter of the Sun
- C** The distance between the Sun and the Earth
- D** The diameter of the Earth

(Total for Question 5 = 1 mark)

DO NOT WRITE IN THIS AREA

DO NOT WRITE IN THIS AREA

DO NOT WRITE IN THIS AREA



- 6 A container is filled with a mixture of two gases, X and Y.

The root mean square velocity of molecules in gas X is twice the root mean square velocity of molecules in gas Y.

The temperature of the gas mixture is constant.

What is the ratio  $\frac{\text{mass of molecules of gas X}}{\text{mass of molecules of gas Y}}$  ?

- A  $\frac{1}{4}$
- B  $\frac{1}{\sqrt{2}}$
- C  $\frac{1}{2}$
- D 1

(Total for Question 6 = 1 mark)

- 7 The value of the Hubble constant,  $H_0$ , was initially estimated to be  $1.5 \times 10^{-17} \text{ s}^{-1}$ .  
Using this initial value, the age of the universe is  $T$ .

Scientists now estimate  $H_0$  to be  $2.1 \times 10^{-18} \text{ s}^{-1}$ .

Which of the following is the age of the universe using this value of  $H_0$ ?

- A  $0.14T$
- B  $0.71T$
- C  $1.4T$
- D  $7.1T$

(Total for Question 7 = 1 mark)

DO NOT WRITE IN THIS AREA

DO NOT WRITE IN THIS AREA

DO NOT WRITE IN THIS AREA



- 8 A pendulum is made by attaching a light paper cone to a thin string, as shown.

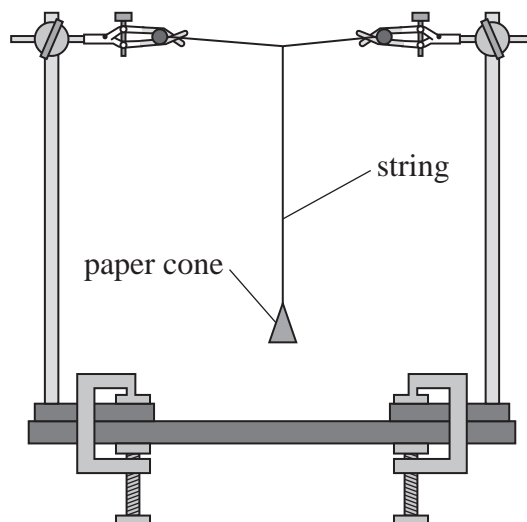

The pendulum is displaced and set into oscillation.

Plasticine is then added to the paper cone to increase the mass of the pendulum.

The pendulum is set into oscillation again.

Which of the following is correct for the paper cone with plasticine?

- A The frequency of oscillation has decreased.
- B The period of oscillation has increased.
- C The amplitude of oscillation decreased more quickly.
- D The amplitude of oscillation decreased more slowly.

(Total for Question 8 = 1 mark)

- 9 Due to tidal action, the Moon is slowly moving away from the Earth.

As the Moon moves away from the Earth, the gravitational force between the Earth and the Moon changes. The gravitational potential energy of the Moon also changes.

Which row of the table correctly shows these changes?

	Gravitational force between the Earth and the Moon	Gravitational potential energy of the Moon
<input type="checkbox"/> A	decreases	decreases
<input type="checkbox"/> B	decreases	increases
<input type="checkbox"/> C	increases	decreases
<input type="checkbox"/> D	increases	increases

(Total for Question 9 = 1 mark)

10 Energy is supplied at a constant rate to a material. The material is initially solid.

As energy is supplied, the solid melts to form a liquid and finally the liquid turns into a gas. The mass remains constant during the heating process.

The graph shows how the temperature changed with time.

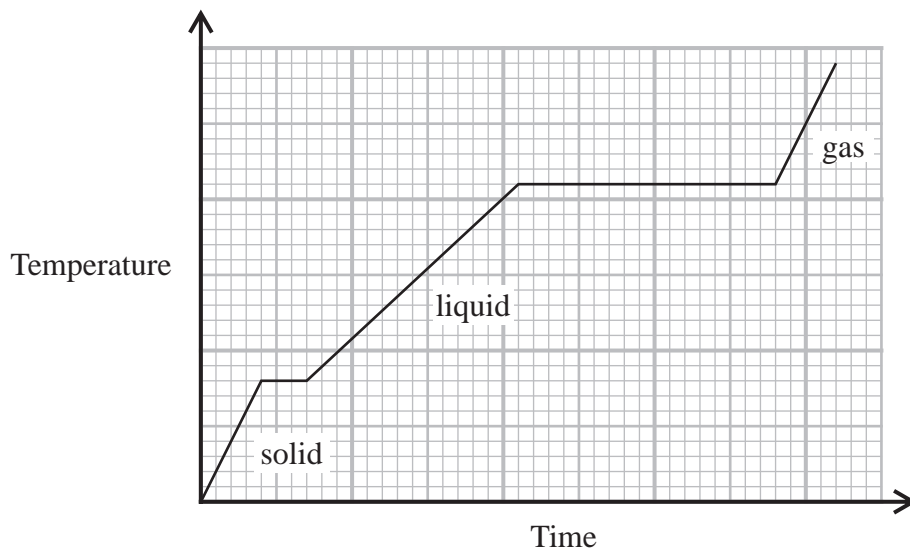

Which of the following is correct?

- A specific heat capacity of solid  $>$  specific heat capacity of liquid
- B specific heat capacity of solid  $>$  specific heat capacity of gas
- C specific heat capacity of solid = specific heat capacity of liquid
- D specific heat capacity of solid = specific heat capacity of gas

(Total for Question 10 = 1 mark)

**TOTAL FOR SECTION A = 10 MARKS**



**SECTION B****Answer ALL questions in the spaces provided.**

- 11** A mass of 0.35 kg is hung from a spring. The mass is displaced vertically from its equilibrium position and released. The mass oscillates vertically with simple harmonic motion with a period of 0.95 s.

An extra mass is added and the period increases to 1.15 s.

Calculate the added mass.

.....

.....

.....

.....

.....

Added mass = .....

**(Total for Question 11 = 3 marks)**

DO NOT WRITE IN THIS AREA

DO NOT WRITE IN THIS AREA

DO NOT WRITE IN THIS AREA



12 The graph shows how gravitational potential  $V$  varies with distance  $r$  from the centre of the Earth.

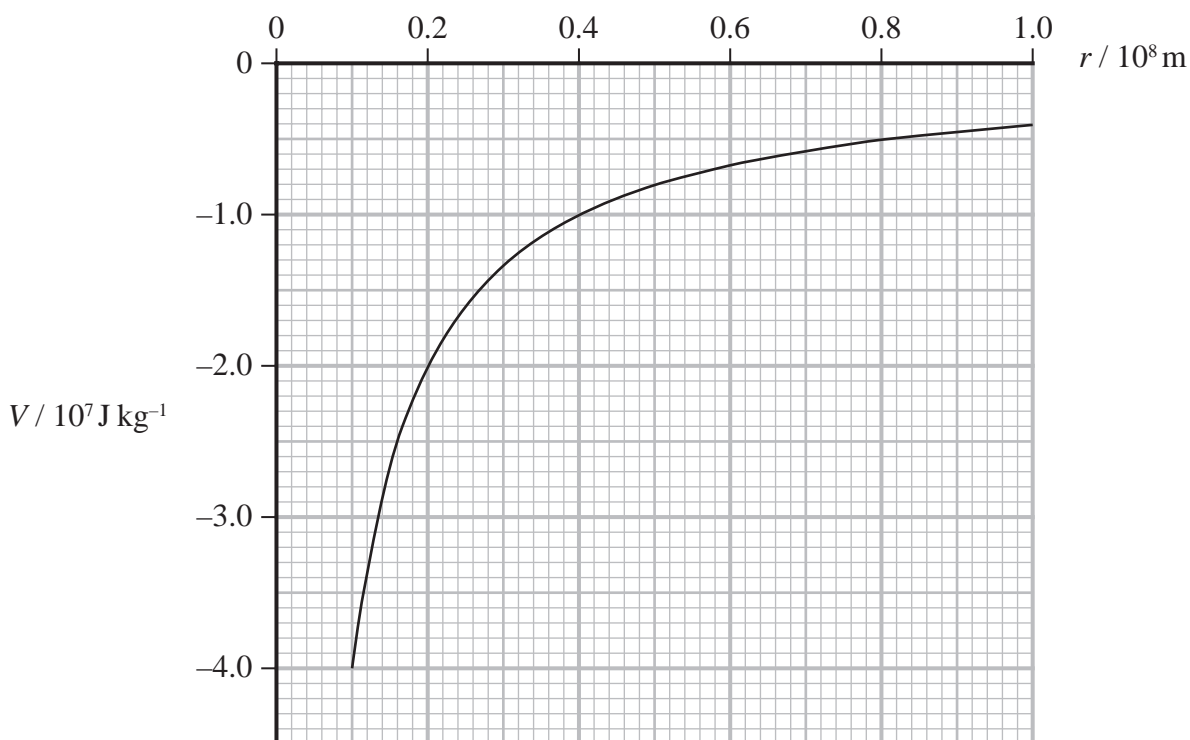

Show that the mass of the Earth is about  $6 \times 10^{24} \text{ kg}$ .

.....

.....

.....

.....

.....

.....

.....

(Total for Question 12 = 3 marks)

DO NOT WRITE IN THIS AREA

DO NOT WRITE IN THIS AREA

DO NOT WRITE IN THIS AREA



13 A pan of water is heated on a 'hot-plate', as shown.

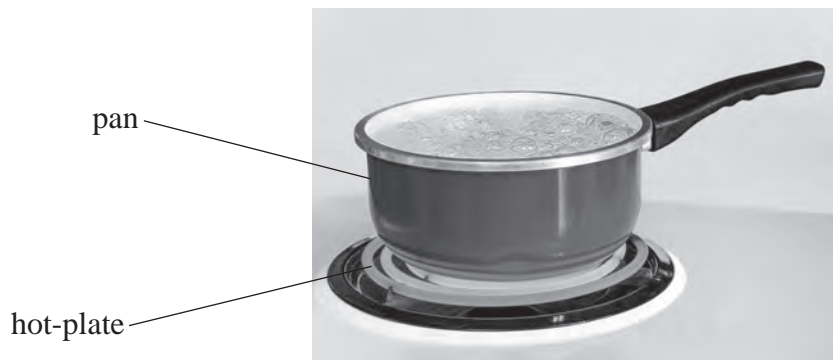

(Source: © Carolyn Franks / Alamy Stock Photo)

- (a) A mass of 0.65 kg of water is boiled away in a time of 1250 s. The power of the hot-plate is 1800 W.

Calculate the efficiency of the boiling process.

specific latent heat of vaporisation of water =  $2.26 \times 10^6 \text{ J kg}^{-1}$

(4)

Efficiency of boiling process = .....

- (b) Putting a lid on a boiling pan reduces the energy transfer needed from the hot-plate to keep the water boiling.

Explain why.

(2)

(Total for Question 13 = 6 marks)



14 The Earth takes 365 days to make one complete orbit of the Sun.

(a) Show that the mass of the Sun is about  $2 \times 10^{30}$  kg.

radius of Earth's orbit about Sun =  $1.49 \times 10^{11}$  m

1 year =  $3.15 \times 10^7$  s

(3)

DO NOT WRITE IN THIS AREA

DO NOT WRITE IN THIS AREA

DO NOT WRITE IN THIS AREA

(b) A television programme claimed that the gravitational field strength at the surface of the Sun is 28 times the gravitational field strength at the surface of the Earth.

Deduce whether this claim is correct.

diameter of Sun =  $1.39 \times 10^9$  m

(3)

(Total for Question 14 = 6 marks)



DO NOT WRITE IN THIS AREA

DO NOT WRITE IN THIS AREA

DO NOT WRITE IN THIS AREA

\*15 The Millennium Bridge, as shown, is a suspension bridge for people to cross the River Thames in London.



(Source: © cowardlion/Shutterstock)

The bridge developed a large swaying motion when people walked across. Dampers were fitted to the bridge to correct the swaying motion.

Explain the cause of the large swaying motion and the effect of the dampers.

Area with horizontal dotted lines for writing the answer.

(Total for Question 15 = 6 marks)



P 7 8 4 7 9 A 0 1 1 3 2

16 Cepheid variable stars are used by astronomers as standard candles.

(a) State what is meant by a standard candle.

(1)

(b) The luminosity of Cepheid variable stars varies periodically.

There is a linear relationship between the period and the mean luminosity of a Cepheid variable star, as shown.

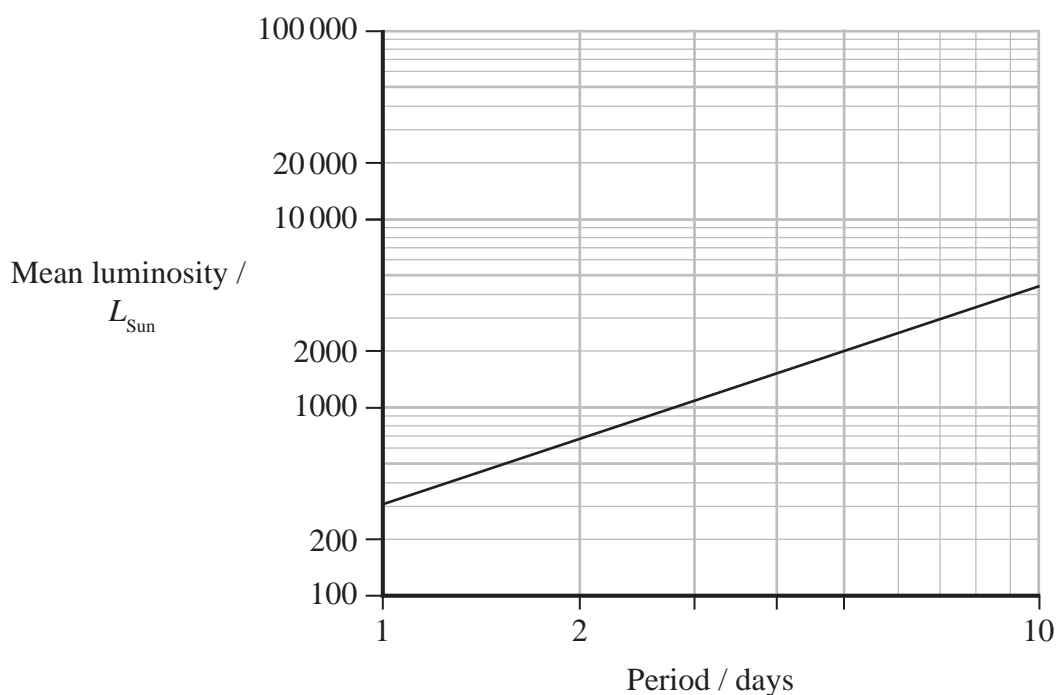

(i) The variation in luminosity  $L$  of this Cepheid variable star with time  $t$  is shown below.

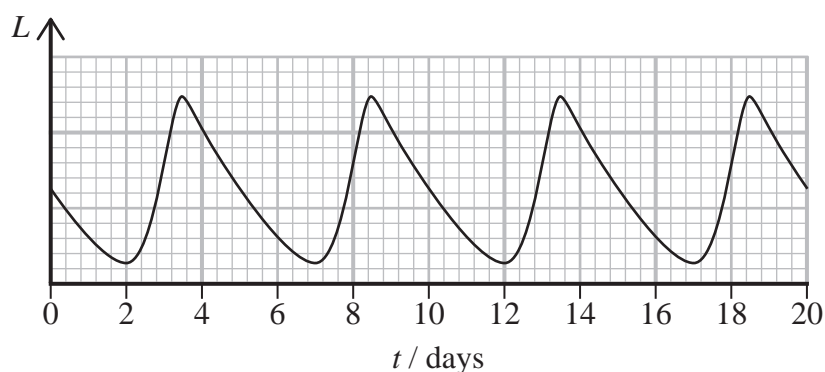

Show that the mean luminosity of this Cepheid variable star is about  $8 \times 10^{29} \text{ W}$ .

$$L_{\text{Sun}} = 3.83 \times 10^{26} \text{ W} \quad (4)$$

- (ii) When viewed from Earth, the mean intensity of this Cepheid variable star is  $5.1 \times 10^{-4} \text{ W m}^{-2}$ .

Determine the distance of this Cepheid variable star from Earth. (2)

Distance of this Cepheid variable star from Earth = .....

**(Total for Question 16 = 7 marks)**

DO NOT WRITE IN THIS AREA

DO NOT WRITE IN THIS AREA

DO NOT WRITE IN THIS AREA



P 7 8 4 7 9 A 0 1 3 3 2

- 17 The graph shows how the acceleration  $a$  of an object varies with the displacement  $x$  of the object from its equilibrium position.

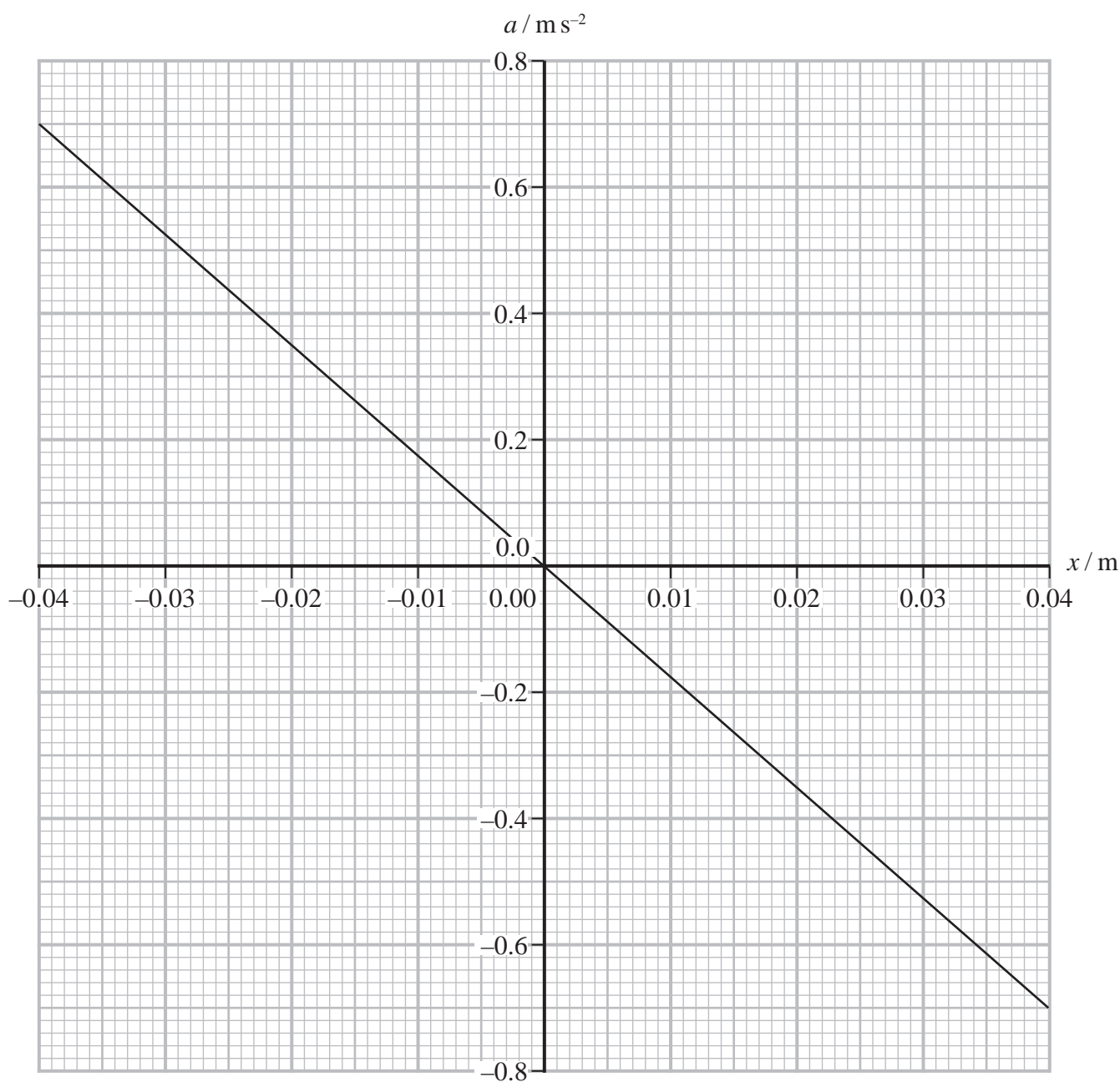

- (a) Explain how the graph shows that the mass is moving with simple harmonic motion.

(2)

.....

.....

.....

.....



DO NOT WRITE IN THIS AREA

(b) (i) Calculate the maximum kinetic energy of the object.

mass of object = 0.25 kg

(5)

.....

.....

.....

.....

.....

.....

.....

.....

.....

.....

Maximum kinetic energy of object = .....

(ii) Sketch a graph on the axes below to show how the kinetic energy of the object varies with displacement  $x$ .

You do not need to do any more calculations.

(2)

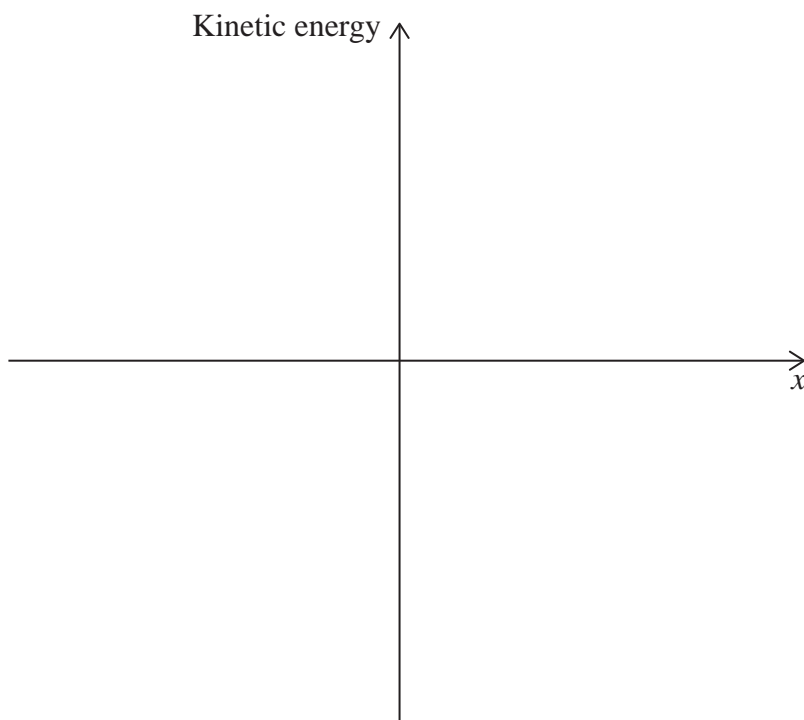

(Total for Question 17 = 9 marks)



- 18 The diagram shows dark lines in the continuous spectrum of electromagnetic radiation from the Sun.

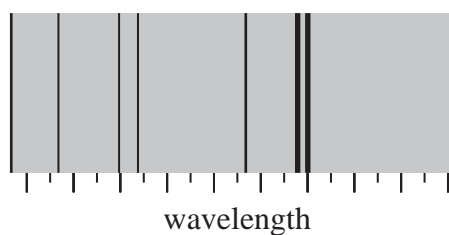

- (a) Atoms in the outer regions of the Sun absorb electromagnetic radiation. This produces the dark lines in the spectrum.

Explain why electromagnetic radiation is only absorbed at some wavelengths.

(3)

.....

.....

.....

.....

.....

.....

DO NOT WRITE IN THIS AREA

DO NOT WRITE IN THIS AREA

DO NOT WRITE IN THIS AREA



(b) The Sun rotates on its axis. The diagram shows the Sun rotating at its 'equator'.

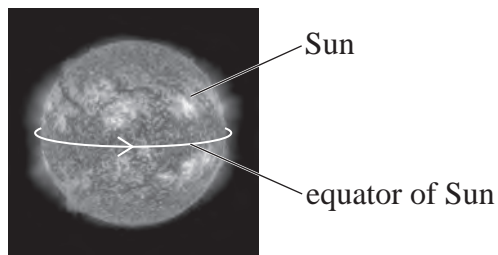

(Source: © NASA / SDO / SCIENCE PHOTO LIBRARY)

One of the dark lines in the spectrum occurs at a wavelength of 589 nm.

Radiation is received on Earth from opposite ends of the Sun's diameter. There is a difference between the wavelengths of radiation received from opposite ends due to the Sun rotating about its axis.

The difference in wavelength is  $7.94 \times 10^{-3}$  nm.

A website states that at its equator, the Sun rotates once every 27 days about its axis.

Assess the accuracy of this statement.

radius of Sun =  $6.96 \times 10^8$  m

1 day =  $8.64 \times 10^4$  s

(5)

(Total for Question 18 = 8 marks)



19 A filament bulb contains argon gas to extend the lifetime of the filament.

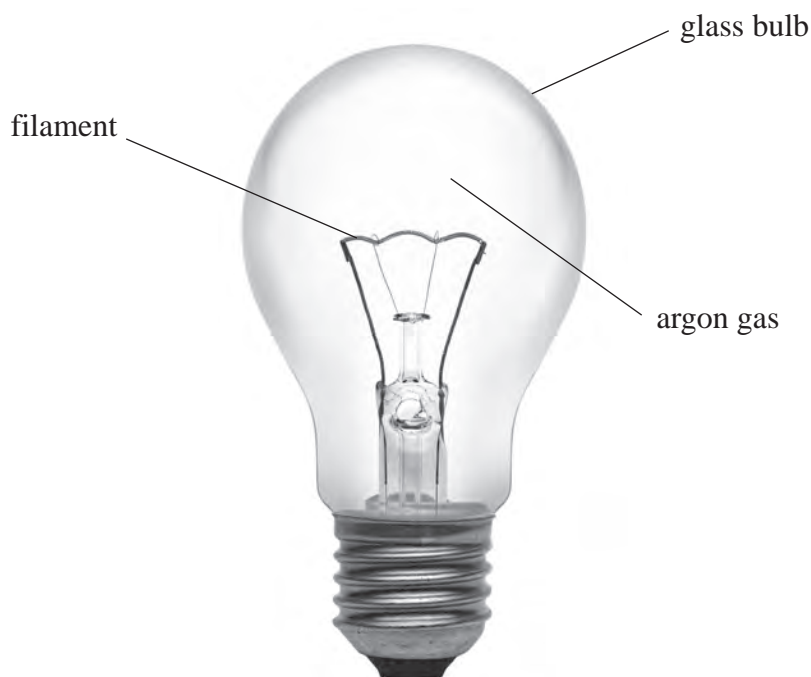

(Source: © mauritius images GmbH / Alamy Stock Photo)

While the bulb is off, the argon gas inside the bulb is at a temperature of 290 K. The pressure of the argon gas inside the bulb is 75% of atmospheric pressure.

$$\text{volume of bulb} = 1.25 \times 10^{-4} \text{ m}^3$$

$$\text{atmospheric pressure} = 1.03 \times 10^5 \text{ Pa}$$

(a) Calculate the number of argon atoms in the bulb.

(3)

.....

.....

.....

.....

.....

.....

.....

Number of argon atoms = .....



- (b) While the bulb is on, the pressure of the argon gas is 83% of atmospheric pressure.

The manufacturer states that the temperature of the gas inside the bulb is about  $60^{\circ}\text{C}$  while the bulb is on.

Assess whether this statement is accurate.

(3)

- (c) (i) While the bulb is on, radiation is emitted by the filament. This radiation has a peak power output at a wavelength,  $\lambda_{\text{max}}$ , of 1100 nm.

Calculate the power output of the bulb.

surface area of filament =  $1.55 \times 10^{-5} \text{ m}^2$

(3)

Power output of bulb = .....

- (ii) Suggest why the actual power output of the bulb may be lower than the value calculated.

(1)

(Total for Question 19 = 10 marks)



P 7 8 4 7 9 A 0 1 9 3 2

- 20 Fifty years ago Henri Peteri developed a device, for the kitchen, that produces instant boiling water. A modern version is shown.

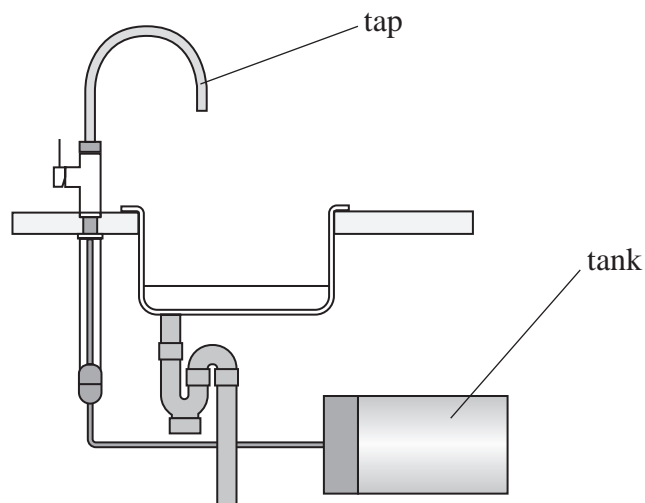

The system consists of a small tank connected to the water supply. Water in the tank is heated under pressure to a temperature of  $110^{\circ}\text{C}$ .

When the water flows out of the tap, the temperature falls to  $100^{\circ}\text{C}$ .

- (a) Water enters the tank at a temperature of  $12^{\circ}\text{C}$ . An electrical heater increases the temperature of the water to  $110^{\circ}\text{C}$ . The water does not boil because it is under pressure.

Calculate the time taken to heat a full tank of water to  $110^{\circ}\text{C}$ .

potential difference across heater =  $230\text{ V}$

current in heater =  $12.6\text{ A}$

volume of tank =  $3.0 \times 10^{-3}\text{ m}^3$

density of water =  $997\text{ kg m}^{-3}$

specific heat capacity of water =  $4180\text{ J kg}^{-1}\text{ K}^{-1}$

(5)

.....

.....

.....

.....

.....

.....

.....

.....

.....

.....

Time taken to heat water = .....



DO NOT WRITE IN THIS AREA

DO NOT WRITE IN THIS AREA

DO NOT WRITE IN THIS AREA



21 Promethium is produced as a byproduct of nuclear fission. An isotope of promethium, Pm-147, decays by beta emission.

- (a) The thickness of paper produced in a paper mill can be monitored using beta radiation, as shown.

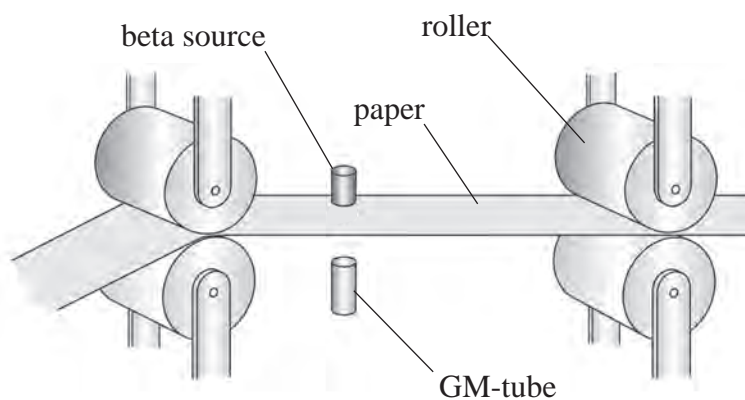

(Source: SCIENCE PHOTO LIBRARY)

The count rate recorded by the GM-tube is a measure of the thickness of the paper.

- (i) Explain why a source of beta radiation is suitable to monitor the thickness of the paper.

(2)

- (ii) Pm-147 decays by beta decay to an isotope of samarium, Sm.

Complete the decay equation.

(2)



(iii) In a particular paper mill, the Pm source was replaced when the activity of the source had decreased to 0.75% of its initial activity.

Calculate the time that the source had been in use.

half-life of Pm-147 = 2.62 years

(4)

.....

.....

.....

.....

.....

.....

.....

.....

.....

.....

Time source had been in use = .....

DO NOT WRITE IN THIS AREA

DO NOT WRITE IN THIS AREA

DO NOT WRITE IN THIS AREA





### List of data, formulae and relationships

Acceleration of free fall	$g = 9.81 \text{ m s}^{-2}$	(close to Earth's surface)
Boltzmann constant	$k = 1.38 \times 10^{-23} \text{ J K}^{-1}$	
Coulomb's law constant	$k = 1/4\pi\epsilon_0$ $= 8.99 \times 10^9 \text{ N m}^2 \text{ C}^{-2}$	
Electron charge	$e = -1.60 \times 10^{-19} \text{ C}$	
Electron mass	$m_e = 9.11 \times 10^{-31} \text{ kg}$	
Electronvolt	$1 \text{ eV} = 1.60 \times 10^{-19} \text{ J}$	
Gravitational constant	$G = 6.67 \times 10^{-11} \text{ N m}^2 \text{ kg}^{-2}$	
Gravitational field strength	$g = 9.81 \text{ N kg}^{-1}$	(close to Earth's surface)
Permittivity of free space	$\epsilon_0 = 8.85 \times 10^{-12} \text{ F m}^{-1}$	
Planck constant	$h = 6.63 \times 10^{-34} \text{ J s}$	
Proton mass	$m_p = 1.67 \times 10^{-27} \text{ kg}$	
Speed of light in a vacuum	$c = 3.00 \times 10^8 \text{ m s}^{-1}$	
Stefan-Boltzmann constant	$\sigma = 5.67 \times 10^{-8} \text{ W m}^{-2} \text{ K}^{-4}$	
Unified atomic mass unit	$u = 1.66 \times 10^{-27} \text{ kg}$	

#### Unit 1

##### Mechanics

Kinematic equations of motion	$s = \frac{(u + v)t}{2}$
	$v = u + at$
	$s = ut + \frac{1}{2}at^2$
	$v^2 = u^2 + 2as$

Forces	$\Sigma F = ma$
	$g = \frac{F}{m}$
	$W = mg$

Momentum	$p = mv$
----------	----------

Moment of force	moment = $Fx$
-----------------	---------------

Work and energy	$\Delta W = F\Delta s$
	$E_k = \frac{1}{2}mv^2$

	$\Delta E_{\text{grav}} = mg\Delta h$
--	---------------------------------------

Power	$P = \frac{E}{t}$
	$P = \frac{W}{t}$

DO NOT WRITE IN THIS AREA

DO NOT WRITE IN THIS AREA

DO NOT WRITE IN THIS AREA



P 7 8 4 7 9 A 0 2 5 3 2

Efficiency

$$\text{efficiency} = \frac{\text{useful energy output}}{\text{total energy input}}$$

$$\text{efficiency} = \frac{\text{useful power output}}{\text{total power input}}$$

*Materials*

Density

$$\rho = \frac{m}{V}$$

Stokes' law

$$F = 6\pi\eta rv$$

Hooke's law

$$\Delta F = k\Delta x$$

Elastic strain energy

$$\Delta E_{\text{el}} = \frac{1}{2}F\Delta x$$

Young modulus

$$E = \frac{\sigma}{\varepsilon} \text{ where}$$

$$\text{Stress } \sigma = \frac{F}{A}$$

$$\text{Strain } \varepsilon = \frac{\Delta x}{x}$$

DO NOT WRITE IN THIS AREA

DO NOT WRITE IN THIS AREA

DO NOT WRITE IN THIS AREA



**Unit 2***Waves*

Wave speed

$$v = f\lambda$$

Speed of a transverse wave  
on a string

$$v = \sqrt{\frac{T}{\mu}}$$

Intensity of radiation

$$I = \frac{P}{A}$$

Refractive index

$$n_1 \sin \theta_1 = n_2 \sin \theta_2$$

$$n = \frac{c}{v}$$

Critical angle

$$\sin C = \frac{1}{n}$$

Diffraction grating

$$n\lambda = d \sin \theta$$

*Electricity*

Potential difference

$$V = \frac{W}{Q}$$

Resistance

$$R = \frac{V}{I}$$

Electrical power, energy

$$P = VI$$

$$P = I^2R$$

$$P = \frac{V^2}{R}$$

$$W = VI t$$

Resistivity

$$R = \frac{\rho l}{A}$$

Current

$$I = \frac{\Delta Q}{\Delta t}$$

$$I = nqvA$$

Resistors in series

$$R = R_1 + R_2 + R_3$$

Resistors in parallel

$$\frac{1}{R} = \frac{1}{R_1} + \frac{1}{R_2} + \frac{1}{R_3}$$

*Particle nature of light*

Photon model

$$E = hf$$

Einstein's photoelectric  
equation

$$hf = \phi + \frac{1}{2}mv_{\max}^2$$

de Broglie wavelength

$$\lambda = \frac{h}{p}$$

DO NOT WRITE IN THIS AREA

DO NOT WRITE IN THIS AREA

DO NOT WRITE IN THIS AREA



P 7 8 4 7 9 A 0 2 7 3 2

**Unit 4***Further mechanics*

Impulse

$$F\Delta t = \Delta p$$

Kinetic energy of a non-relativistic particle

$$E_k = \frac{p^2}{2m}$$

Motion in a circle

$$v = \omega r$$

$$T = \frac{2\pi}{\omega}$$

$$a = \frac{v^2}{r}$$

$$a = r\omega^2$$

Centripetal force

$$F = ma = \frac{mv^2}{r}$$

$$F = mr\omega^2$$

*Electric and magnetic fields*

Electric field

$$E = \frac{F}{Q}$$

Coulomb's law

$$F = \frac{Q_1 Q_2}{4 \pi \epsilon_0 r^2}$$

$$E = \frac{Q}{4 \pi \epsilon_0 r^2}$$

$$E = \frac{V}{d}$$

Electrical potential

$$V = \frac{Q}{4 \pi \epsilon_0 r}$$

Capacitance

$$C = \frac{Q}{V}$$

Energy stored in capacitor

$$W = \frac{1}{2} QV$$

$$W = \frac{1}{2} CV^2$$

$$W = \frac{1}{2} \frac{Q^2}{C}$$

Capacitor discharge

$$Q = Q_0 e^{-t/RC}$$

DO NOT WRITE IN THIS AREA

DO NOT WRITE IN THIS AREA

DO NOT WRITE IN THIS AREA



Resistor-capacitor discharge

$$I = I_0 e^{-t/RC}$$

$$V = V_0 e^{-t/RC}$$

$$\ln Q = \ln Q_0 - \frac{t}{RC}$$

$$\ln I = \ln I_0 - \frac{t}{RC}$$

$$\ln V = \ln V_0 - \frac{t}{RC}$$

In a magnetic field

$$F = Bqv \sin \theta$$

$$F = BIl \sin \theta$$

Faraday's and Lenz's laws

$$\mathcal{E} = \frac{-d(N\phi)}{dt}$$

*Nuclear and particle physics*

In a magnetic field

$$r = \frac{p}{BQ}$$

Mass-energy

$$\Delta E = c^2 \Delta m$$

DO NOT WRITE IN THIS AREA

DO NOT WRITE IN THIS AREA

DO NOT WRITE IN THIS AREA



P 7 8 4 7 9 A 0 2 9 3 2

**Unit 5***Thermodynamics*

Heating  $\Delta E = mc\Delta\theta$

$$\Delta E = L\Delta m$$

Ideal gas equation  $pV = NkT$

Molecular kinetic theory  $\frac{1}{2}m\langle c^2 \rangle = \frac{3}{2}kT$

*Nuclear decay*

Mass-energy  $\Delta E = c^2\Delta m$

Radioactive decay  $A = \lambda N$

$$\frac{dN}{dt} = -\lambda N$$

$$\lambda = \frac{\ln 2}{t_{1/2}}$$

$$N = N_0 e^{-\lambda t}$$

$$A = A_0 e^{-\lambda t}$$

*Oscillations*

Simple harmonic motion  $F = -kx$

$$a = -\omega^2 x$$

$$x = A \cos \omega t$$

$$v = -A\omega \sin \omega t$$

$$a = -A\omega^2 \cos \omega t$$

$$T = \frac{1}{f} = \frac{2\pi}{\omega}$$

$$\omega = 2\pi f$$

Simple harmonic oscillator  $T = 2\pi\sqrt{\frac{m}{k}}$

$$T = 2\pi\sqrt{\frac{l}{g}}$$

DO NOT WRITE IN THIS AREA

DO NOT WRITE IN THIS AREA

DO NOT WRITE IN THIS AREA



*Astrophysics and cosmology*

Gravitational field strength  $g = \frac{F}{m}$

Gravitational force  $F = \frac{Gm_1m_2}{r^2}$

Gravitational field  $g = \frac{Gm}{r^2}$

Gravitational potential  $V_{\text{grav}} = \frac{-Gm}{r}$

Stefan-Boltzmann law  $L = \sigma AT^4$

Wien's law  $\lambda_{\text{max}}T = 2.898 \times 10^{-3} \text{ m K}$

Intensity of radiation  $I = \frac{L}{4 d^2}$

Redshift of electromagnetic radiation  $z = \frac{\Delta\lambda}{\lambda} \approx \frac{\Delta f}{f} \approx \frac{v}{c}$

Cosmological expansion  $v = H_0 d$

DO NOT WRITE IN THIS AREA

DO NOT WRITE IN THIS AREA

DO NOT WRITE IN THIS AREA



P 7 8 4 7 9 A 0 3 1 3 2

DO NOT WRITE IN THIS AREA

DO NOT WRITE IN THIS AREA

DO NOT WRITE IN THIS AREA

**BLANK PAGE**

